



MODEL

7360R

7360RH

7360RB

PARTS & INSTRUCTION MANUAL

Before putting a new machine into operation, remove the plugs (A) on the top of the arm and replenish the oil supply. Lift the presser foot and run the machine at a low speed of 2000 spm to check that the oil is being distributed correctly by inspecting the window on the oil reservoir. When lubrication is normal, keep the machine running at this speed for 30 minutes, and then increase the running speed gradually. After a month of running, the machine can be run at maximum speed assuming normal working conditions.

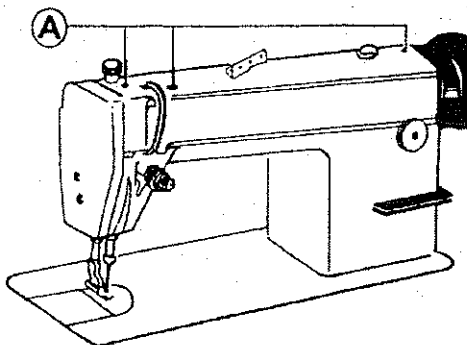

SPECIFICATIONS

MODEL		7360R	7360RH	7360RB
MAX. SEWING SPEED (S. P. M)		5000	3500	3000
STITCH LENGTH		5 mm	7 mm	
PRESSER FOOT LIFT	BY HAND	5 mm		
	BY KNEE	13 mm		
NEEDLE		DB × 1 11 # - 18 #	DP × 5 18# - 22#	
REVERSE SEWING DEVICE		yes		
LUBRICATION		automatic lubrication		

FILLING THE OIL RESERVOIR

The amount of oil in the reservoir is controlled through the reference marks A and B shown in Fig 2. A indicates the maximum oil level, the mark B is the minimum oil level. If the oil level is below the mark B refill the oil reservoir.

When filling the reservoir, loosen the oil draining screw (c), drain off the remaining oil reservoir completely, clean the reservoir and re-tighten the oil draining screw (c) and fill the oil reservoir with fresh sewing machine oil.

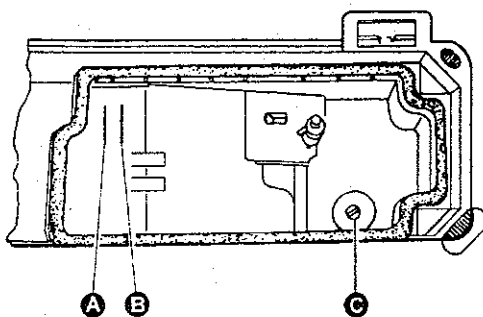

Fig 1

REGULATING OIL DISTRIBUTION ON THE ROTATING HOOK

Adjust the amount of oil used to lubricate the rotating hook by turning the oil flow adjusting screw (A). Turn the screw (A) clockwise (in the direction of the + sign) to increase the oil flow; turn it counter-clockwise (in the direction of the - sign) to decrease the oil flow.

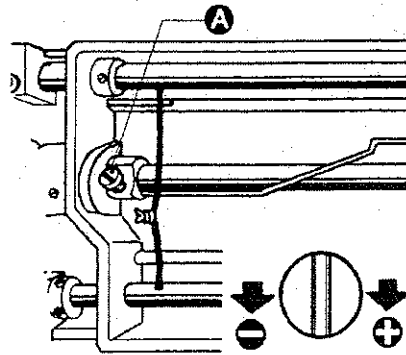

Fig. 2

OIL PUMP ADJUSTMENT

During everyday operation, adjusting the oil pump is not usually necessary. If the oil level doesn't fluctuate in the oil reservoir window when the machine runs at a low speed, close the clearance on the oil bypass hole.

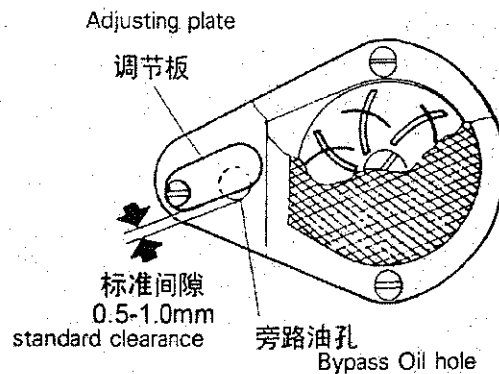

Fig. 4

NEEDLE INSTALLATION

Turn the balance wheel to lift the needle bar to the upper end of its stroke. Loosen the needle clamp screw while keeping the long groove of the needle facing left; insert the needle shank up to the bottom of the needle socket, then tighten the needle clamp screw.

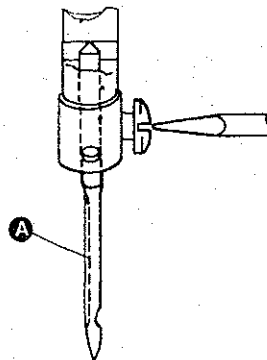

Fig. 5

CONNECTING THE CLUTCH LEVER TO THE PEDAL

The optimum tilt angle of the pedal is approximately 15 degrees.

Adjust the clutch so that the clutch lever (c) aligns with the draw bar (B) as shown

in Fig. 6. The machine pulley should rotate counter clockwise when viewed from the outside of it. The rotating direction of motor pulley can be reversed by turning the plug of the motor 180 degrees.

Adjust the tension of 0-Belt (F) by moving the motor up and down; the proper tension on the 0-belt is a slack of 10-20 mm when the belt is depressed at the center of the belt.

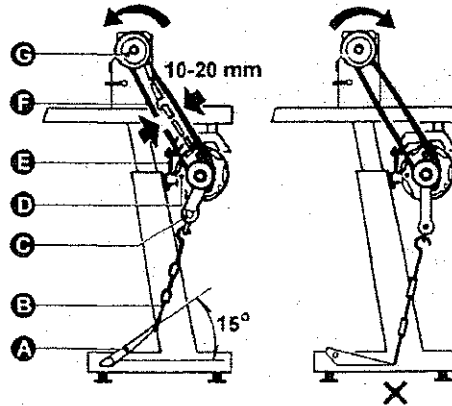

Fig. 6

BELT COVER INSTALLATION

Install the belt cover for the sake of safety.

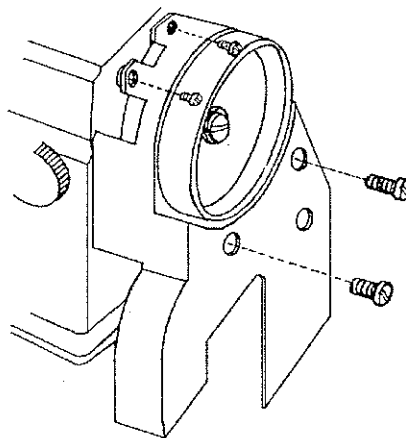

Fig. 7

ADJUSTING THE TIMING OF THE TENSION DISCS

Within the presser foot lift range, the timing of the tension discs can be adjusted as follows:

Remove the rubber plug from the back of the arm and loosen the screw (A) of the knee lift lever (left).

Move the tension releasing cam (D) to the left for earlier opening or to the right for later opening.

It will facilitate the adjustment if a block is put under the presser foot lift.

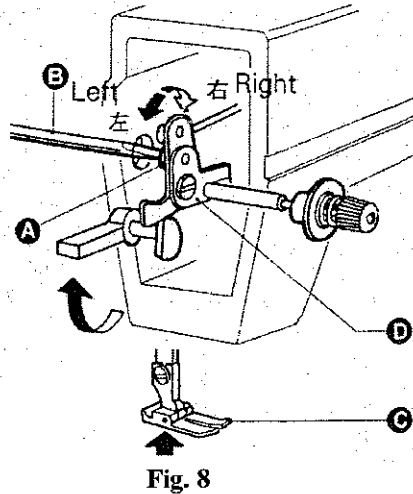

THREADING

To thread the needle, raise the needle bar to the upper end of its stroke. Lead the thread from the spool and follow the progression as shown in Fig. 9. To draw the bobbin thread, hold the end of the needle thread and turn the balance wheel to lower the needle bar and then lift it to its highest position. Pull the ends of needle thread and bobbin thread toward the front and under the presser foot.

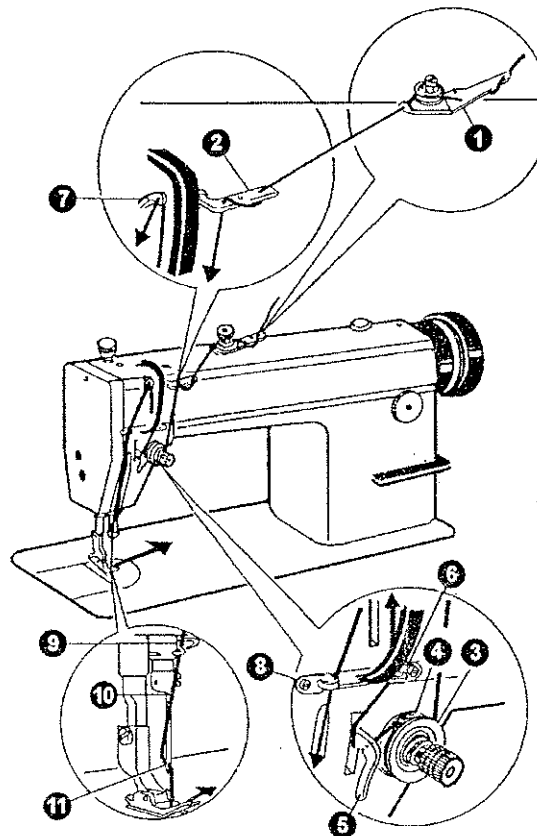

Fig. 9

BOBBIN WINDER INSTALLATION AND ADJUSTMENT

The bobbin winder pulley should align with the V belt and there should be some clearance between them. When the bobbin winder stop latch lever is depressed, the V belt should be in contact with the bobbin winder pulley so that the bobbin winder pulley can be driven by the V belt. The thread on the bobbin should be uniform and tight. If not, turn the tension stud nut (A) on the bobbin winder tension bracket to adjust the tension. First, loosen the set screw (B) on the bobbin winder tension bracket and move the bracket (C) either left or right as needed. For instance, if the thread is wound as illustrated by figure (b), move the bracket left. If it is wound as in figure (c) move it right. After adjusting the tension make sure to tighten set screw (B). Don't overfill the bobbin, figure (d). For best results, fill to about 80% capacity. This can be adjusted by using screw (E).

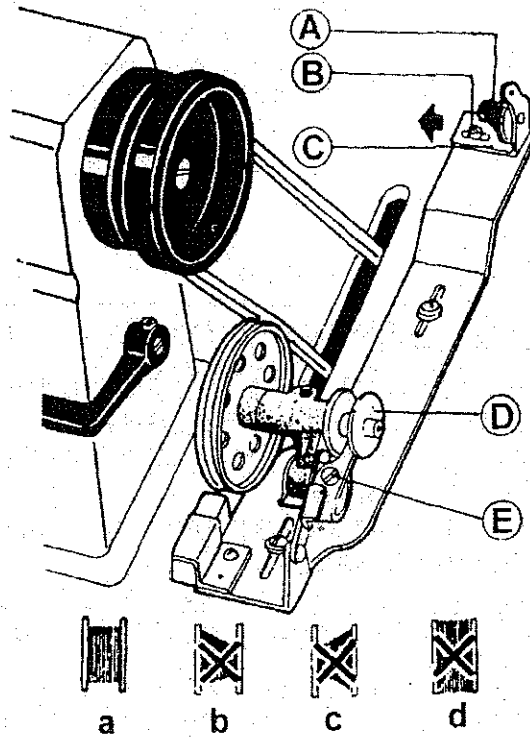
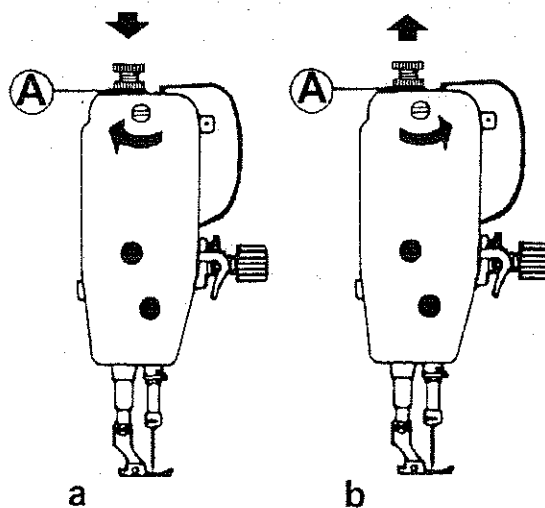

Fig. 10

ADJUSTING THE PRESSURE ON THE PRESSER FOOT

Adjusting the pressure on the presser foot is dependent upon the thickness of the material being sewn. First, loosen lock nut (A). For heavy materials turn the pressure regulating thumb screw in the direction indicated in Fig. 11 (a) to increase the pressure. For light materials turn the thumb screw in the opposite direction as shown in Fig. 11 (b) to decrease the pressure. Once the appropriate pressure has been set tighten lock nut (A)



THREAD TENSION ADJUSTMENT

Thread tension should be determined in tandem with the stitch obtained by adjusting the tension on the bobbin thread and the needle thread Fig. 12. The tension of the bobbin thread should be adjusted by turning the tension spring regulating screw on the bobbin case. Once it is adjusted, insert the bobbin into the bobbin case and hold the end of the thread from the case and let it hang. If the bobbin rotates slowly downward the tension is correct. The tension on the needle thread is adjusted by turning the thumb nut.

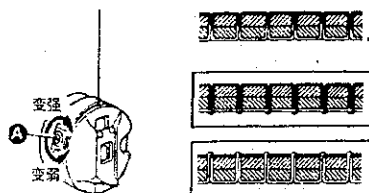

Fig. 12

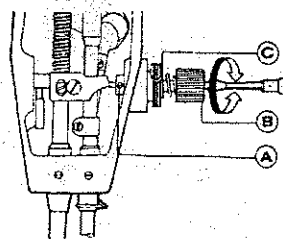
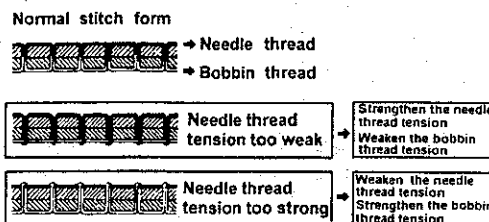
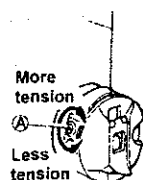

Fig. 13

13

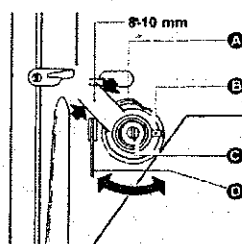

Fig. 14

The stroke of the thread take-up spring runs from 8mm to 10mm. When sewing very thin fabrics, reduce the thread take-up spring tension and increase the thread take-up spring stroke. Conversely increase the thread take-up spring tension and reduce the thread take-up stroke when sewing very thick fabrics.

To adjust the thread take-up spring tension: (Fig. 13), first loosen the set screw (A) then turn the tension stud (B) counter clockwise to decrease the tension of the thread take-up spring (C) to zero. then turn the tension stud (B) clockwise till the spring (C) comes to the notch of the tension regulating bushing, and again turn the tension stud (B) halfway back (counter clockwise), After the adjustment, tighten the set screw (A).

Adjusting the thread take-up spring stroke: (Fig. 14) loosen the set screw (B) turn the stud (C) clockwise to increase the stroke or turn stud (C) counter clockwise to decrease the stroke. After making the adjustment, tighten set screw (B).

SYNCHRONIZING THE NEEDLE WITH THE ROTATING HOOK

When the needle bar is raised from its lowest position the gap should equal that illustrated by (A) in Fig. 15. The hook point (D, Fig. 16) of the bobbin should align with the center line of the needle and be 1- 1.5 mm above upper end of the needle eye (Fig 15).

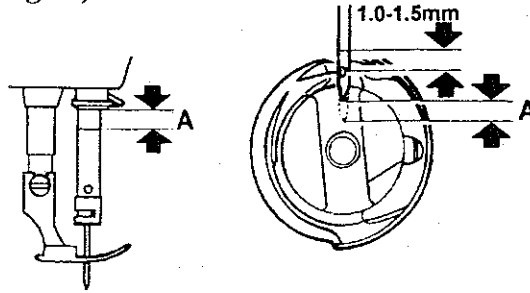

Fig. 15

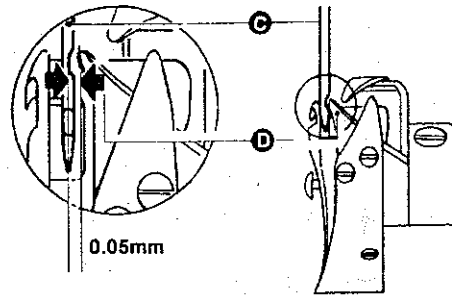

Fig. 16

The clearance between the bottom of the needle notch and the hook point should be approximately 0.05 mm (Fig. 16).

ADJUSTING STITCH LENGTH AND REVERSE FEEDING

The stitch length can be adjusted by turning dial (A). The figures on the face (B) of the dial show the stitch length in mm. The reverse feed lever must be depressed while adjusting the stitch length. Reverse feeding starts when the reverse feed lever (c) is depressed, the machine will feed forward again when the reverse feed lever is released.

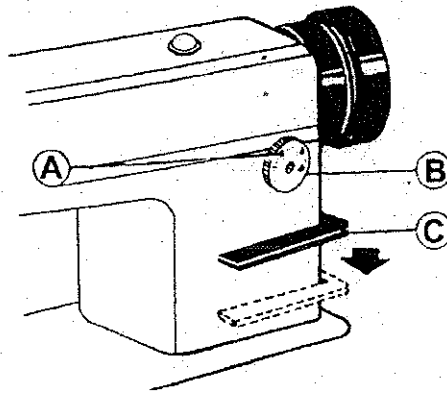

Fig. 17

ADJUSTING SYNCHRONIZATION OF THE NEEDLE WITH THE FEED MOTION

To adjust the feed dog position (G), first should release the two set screw (F) and turn around the balance wheel by hand. When the needle (A) point reaches the surface of the throat plate (B), the top of the feed dog (C) should be flush with the throat plate surface.

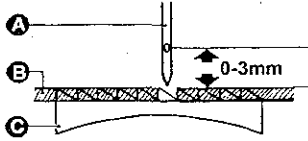

Fig. 18

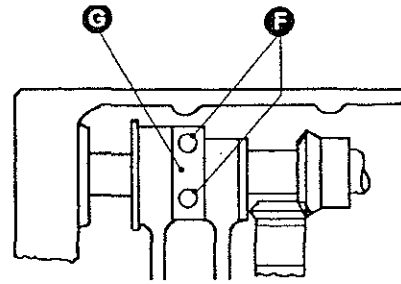

Fig. 19

STITCH LENGTH ADJUSTMENT

Loosen Screw (A) to adjust Stitch Length Adjusting Cam (B). Turn it to the right to narrow the stitch length for forward stitches, and widen it for reverse; turn it left to widen the stitch length for forward stitches, and narrow it for reverse.

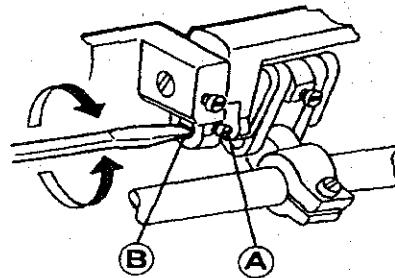

Fig. 20

HORIZONTAL ADJUSTMENT OF THE FEED DOG

Lift the front of the feed dog to prevent the fabric from puckering. Lower the front of the feed dog to prevent the fabric from tearing or the bobbin thread breaking.

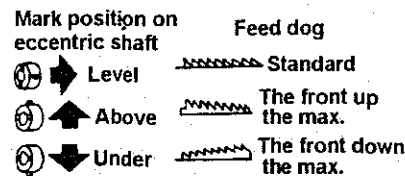

Fig. 21

THREAD TAKE UP LEVER OIL SUPPLY ADJUSTMENT

Before the machine leaves the factory, the thread take-up lever oil supply adjusting pin has already been adjusted to the proper level and the user doesn't need to readjust it. If the amount of oil supplied to the thread take up lever is too much or too little, then an adjustment is needed. Adjust as follows: When the mark on the oil adjusting pin is the upper position, the oil is at the maximum level. (Fig. a) When the dot mark on the oil adjusting pin is the lower position, the oil is at the minimum level. (Fig. b) Using a screwdriver, turn the adjusting pin to either increase or decrease the oil being supplied as illustrated in Fig. c.

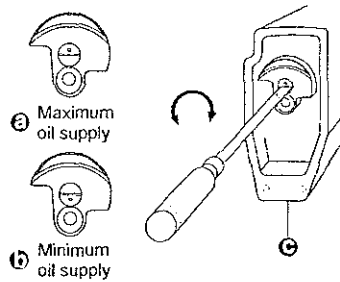
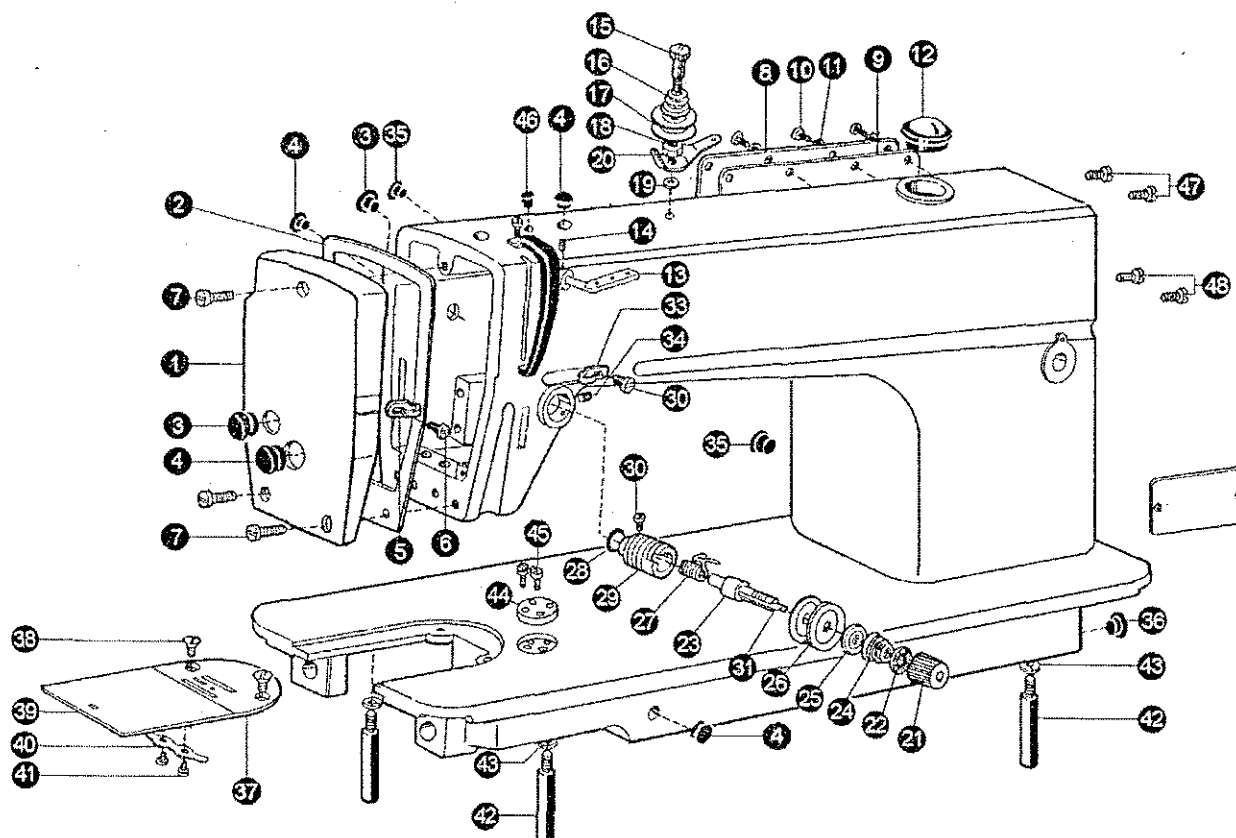

Fig. 22

PARTS CATALOGUE

ARM BED AND ACCESSORIES



No.	Ref. No.	Description	Pcs.		
			M	H	B
1	124T1 -002	Face plate	1	1	1
2	124T1 -003	Gasket for Face plate	1	1	1
3	22T1 -003C3	Rubber plate	1	1	2
4	22T1 -003C4	Rubber plate	4	4	4
5	22T1 -003C5	Thread guide on face plate	1	1	1
6	22T1 -003C6	Thread guide screw	1	1	1
7	22T1 -004	Face plate screw	3	3	3
8	22T1 -005D1	Back plate	1	1	1
9	22T1 -005D2	Gasket for back plate	1	1	1
10	22T1 -006	Set screw	8	8	8
11	22T1 -007	Washer	8	8	8
12	22T1 -008H	Oil check window	1	1	1
13	36T2 -004	Three hole thread guide	1	1	1
14	36T2 -005	Set screw	1	1	1
15	22T1 -009E1	Screw	1	1	1
16	36T2 -006D3	Spring for pre - tension	1	1	1
17	22T1 -009E3	Discs for pre - tension	2	2	2
18	22T1 -009E4	Washer	1	1	1
19	GB896 - 76	Spring washer	1	1	1
20	22T1 -009E5	Thread guide for pre - tension	1	1	1
21	124T1 -003C1	Knub for thread tension regulator	1	1	1
22	22T1 -012F10	Thumb nut revolution stoper	1	1	1
23	22T1 -012F1	Thread tension stud	1	1	1
24	124T1 -003C2	Thread tension spring	1		
	48T1 -003A1	Thread tension spring		1	1

No.	Ref. No.	Description	Pcs		
			M	H	B
25	22T1 -012F4	Thread tension releasing disc	1	1	1
26	22T1 -012F5	Thread tension disc	2	2	2
27	22T1 -012F6	Thread take up spring	1		
	48T1 -003A2	Thread take up spring		1	1
28	22T1 -012F11	Rubber ring	1	1	1
29	22T1 -012F7	Thread tension regulating bushing	1	1	1
30	22T1 -012F8	Set screw	1	1	1
31	22T1 -012F9	Thread tension releasing pin	1	1	1
32	22T1 -013	Set screw	1	1	1
33	22T1 -014	Thread guide for arm center	1	1	1
34	22T1 -003C6	Set screw	1	1	1
35	22T1 -015	Rubber plug	2	2	2
36	22T1 -016	Rubber plug	1	1	1
37	36T2 -008	Needle plate	1		
	48T1 -004	Needle plate		1	
	78T1 -006	Needle plate			1
38	22T1 -020	Needle plate screw	2	2	2
39	22T1 -021G1	Slide plate	1	1	1
40	22T1 -021G2	Spring for slide plate	1	1	1
41	22T1 -021G3	Screw	2	2	2
42	48T1 -005	Log	3	3	3
43	GB93 - 76	Washer	2	2	2
44	57T1 -008	Ruler plate	1	1	1
45	22T2 -004	Ruler screw	2	2	2
46	22T1 -017	Red rubber plug	1	1	1
47	22T1 -006	Screw	2	2	2
48	22T8 -009	Screw	2	2	2

NEEDLE BAR AND THREAD TAKE -UP MECHANISM

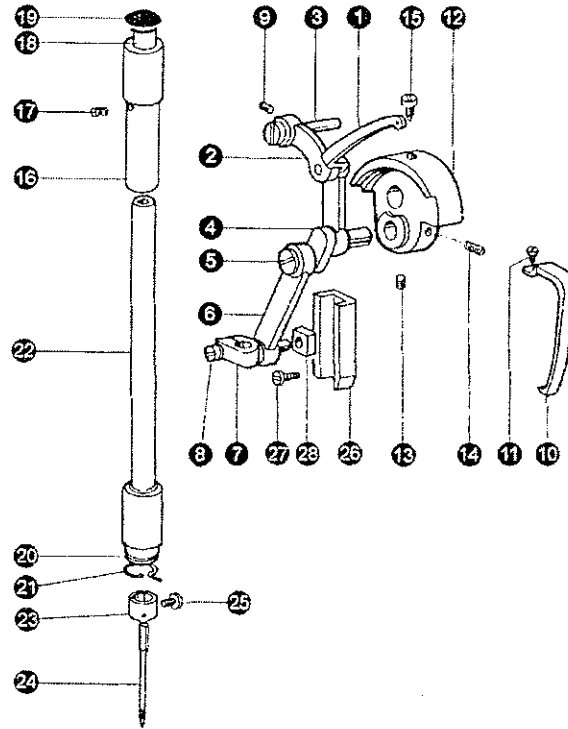

No.	Ref. No.	Description	Pcs.		
			M	H	B
1	124T2 -001A1a	Thread take -up lever	1		
	48T2 -001A1a	Thread take -up lever		1	
	78T2 -001A1a	Thread take -up lever			1
2	22T2 -001A2	Thread take -up link	1	1	1
3	22T2 -001A3	Thread take -up lever hinge pin	1	1	1
4	22T2 -001A4	Thread take -up crank	1	1	1
	22T2 -001A5	Needle roller bearing	2	2	2
5	22T2 -001A6	Set screw (left hand thread)	1	1	1
6	22T2 -001A7b1	Needle bar link ass.	1		
	48T2 -001A2	Needle bar link ass.		1	1
7	22T2 -001A8	Needle bar connecting bar joint	1	1	1
8	22T2 -001A9	Screw	1	1	1
9	22T2 -002	Screw	1	1	1
10	36T2 -007	Take -up lever guard	1	1	
	78T2 -002	Take -up lever guard			1
11	22T2 -004	Screw	1	1	1
12	124T2 -002B1a	Needle bar crank	1		
	124T2 -002B1b	Needle bar crank		1	1
13	22T2 -005B2	Screw	2	2	2
14	22T2 -006	Screw	1	1	1

No.	Ref. No.	Description	Pcs.		
			M	H	B
15	22T2 -007	Thread take -up crank position screw	1	1	1
16	22T2 -008	Needle bar bushing (upper)	1	1	1
17	22T2 -009	Set screw	1	1	1
18	22T2 -010	Felt plug	1	1	1
19	22T2 -011	Red rubber plug (Φ8.8)	1	1	1
20	22T2 -012C1	Needle bar bushing (lower)	1		
	78T2 -003	Needle bar bushing (lower)		1	1
21	124T2 -003C1	Thread guide for needle bar bushing	1	1	1
22	22T2 -014	Needle bar	1		
	48T2 -003	Needle bar		1	1
23	22T2 -015	Thread guide for needle bar	1		
	48T2 -004	Thread guide for needle bar		1	1
24	22T2 -016	Needle (DB x1) 14#	1		
		Needle (DP x5)		1	1
25	22T2 -017	Needle clamp screw	1	1	1
26	22T2 -018	Needle bar connecting link guide	1	1	1
27	22T2 -019	Set screw	2	2	2
28	22T2 -020	Slide block	1	1	1

ARM SHAFT AND VERTICAL SHAFT MECHANISM

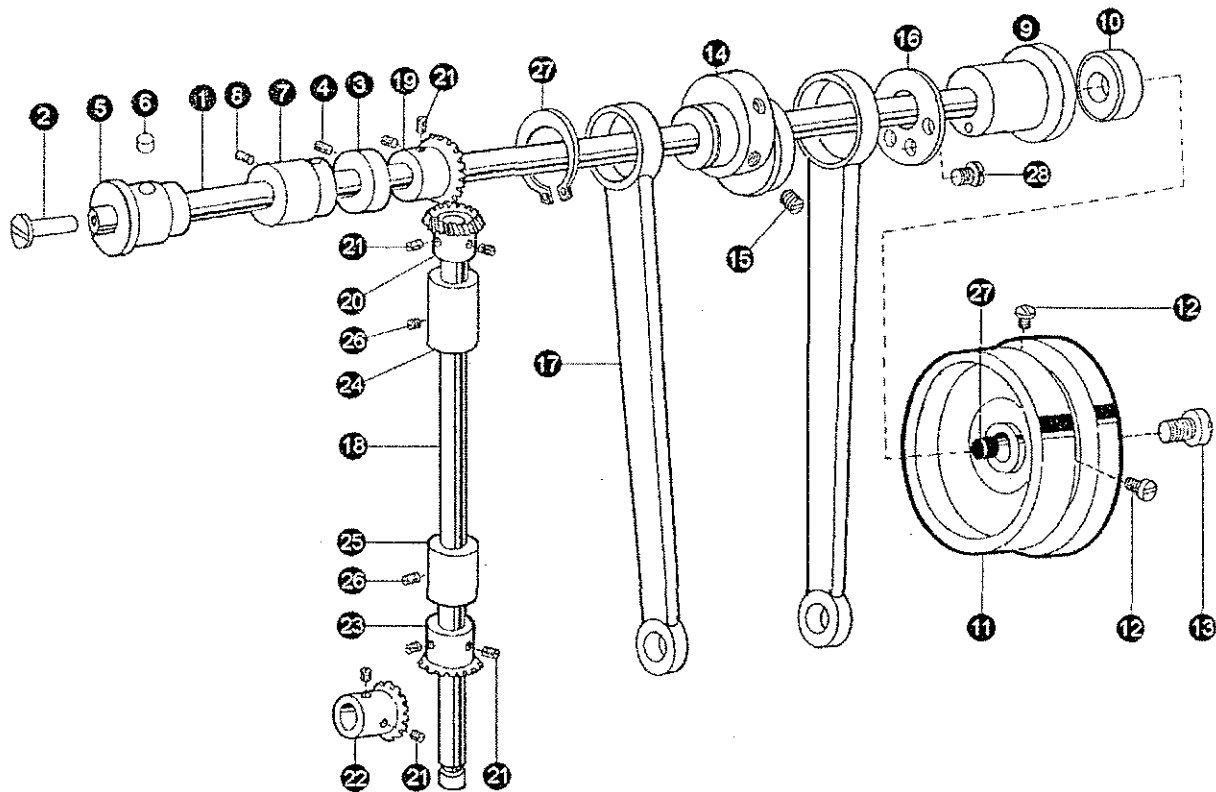

No.	Ref. No.	Description	Pcs.		
			M	H	B
1	124T3 - 001A1	Arm shaft	1	1	1
2	124T3 - 001A2	Adjusting screw	1	1	1
3	22T3 - 002B1	Collar for arm shaft	1	1	1
4	22T3 - 002B2	Set screw	2	2	2
5	124T3 - 002B1	Arm shaft bushing (left)	1	1	1
6	124T3 - 002B2	Oil felt	1	1	1
7	22T3 - 004	Arm shaft bushing (middle)	1	1	1
8	22T2 - 002	Set screw	1	1	1
9	124T3 - 003C1	Arm shaft bushing (right)	1	1	1
10	124T3 - 003C2	Oil seal	1	1	1
11	22T3 - 007C1	Balance wheel	1	1	1
12	22T3 - 007C2	Set screw	2	2	2
13	22T3 - 008	Set screw	1	1	1
14	36T3 - 003	Eccentric wheel	1		
	114T3 - 001	Eccentric wheel		1	1

No	Ref. No.	Description	Pcs.		
			M	H	B
15	22T1 - 013	Eccentric wheel screw	2	2	2
16	36T3 - 004	Spacer	1	1	1
17	22T3 - 009D1c	Crank rod for feed lifting rock shaft	1	1	1
18	22T3 - 010E1	Vertical shaft	1	1	1
19	22T3 - 010E2a1 - 2	Bevel gear for arm shaft	1	1	1
20	22T3 - 010E2a2 - 2	Bevel gear for vertical shaft (upper)	1	1	1
21	22T2 - 005B3	Set screw	8	8	8
22	22T3 - 010E2b1 - 2	Bevel gear for hook shaft	1	1	1
23	22T3 - 010E2b2 - 2	Bevel gear for vertical shaft (lower)	1	1	1
24	22T3 - 011	Vertical shaft bushing (upper)	1	1	1
25	22T3 - 011	Vertical shaft bushing (lower)	1	1	
	78T3 - 001	Vertical shaft bushing (lower)			1
26	22T2 - 002	Set screw	2	2	2
27	36T3 - 004	Spacer	1	1	1
28	100T6 - 012	Screw	3	3	3
29	22T3 - 001A2	Arm shaft rubber plug	1	1	1

ROTATING HOOK MECHANISM

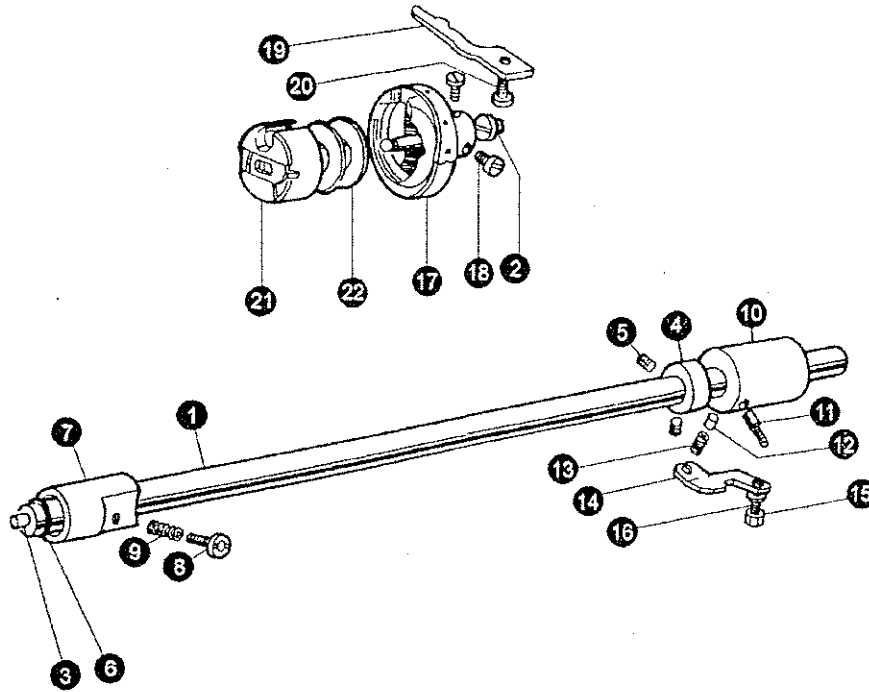

No.	Ref. No.	Description	Pcs.		
			M	H	B
1	36T4 - 008D1	Rotating hook shaft	1	1	
	120T4 - 001	Rotating hook shaft			1
2	22T4 - 001A1a1	Filter screw	1	1	1
3	22T4 - 001A1a2	Filter	1	1	1
4	22T4 - 002B1	Collar for hook shaft	1	1	1
5	22T2 - 009	Set screw	2	2	2
6	22T4 - 003G	Oil seal for rotating hook shaft	1	1	1
7	22T4 - 004	Hook shaft bushing (lift)	1	1	1
8	22T4 - 005	Oil adjusting screw	1	1	1
9	22T4 - 006	Spring for oil adjuster	1	1	1
10	36T4 - 014F1	Hook shaft bushing (right)	1	1	1
11	22T4 - 007C2	Oil pipe for hook shaft bushing	1	1	1
12	36T4 - 015	Plunger	1	1	1
13	36T4 - 016	Plunger spring	1	1	1
14	22T4 - 010	Guide plate	1	1	1
15	22T8 - 009	Screw	1	1	1

No.	Ref. No.	Description	Pcs.		
			M	H	B
16	GB93 - 76	Spring washer	1	1	1
17	22T4 - 011D	Rotating hook	1		
	48T4 - 001A	Rotating hook		1	
	78T4 - 002	Rotating hook			1
18		Screw	2	2	2
19	22T4 - 013	Rotating hook positioner	1		
	48T4 - 002	Rotating hook positioner		1	
	78T4 - 003	Rotating hook positioner			1
20	22T4 - 015	Screw	1	1	1
21	22T4 - 016F	Bobbin case	1	1	
	78T4 - 004F	Bobbin case			1
22	22T4 - 017	Bobbin	1	1	
	78T4 - 005	Bobbin			1

FEEDING AND FEED LIFTING MECHANISM

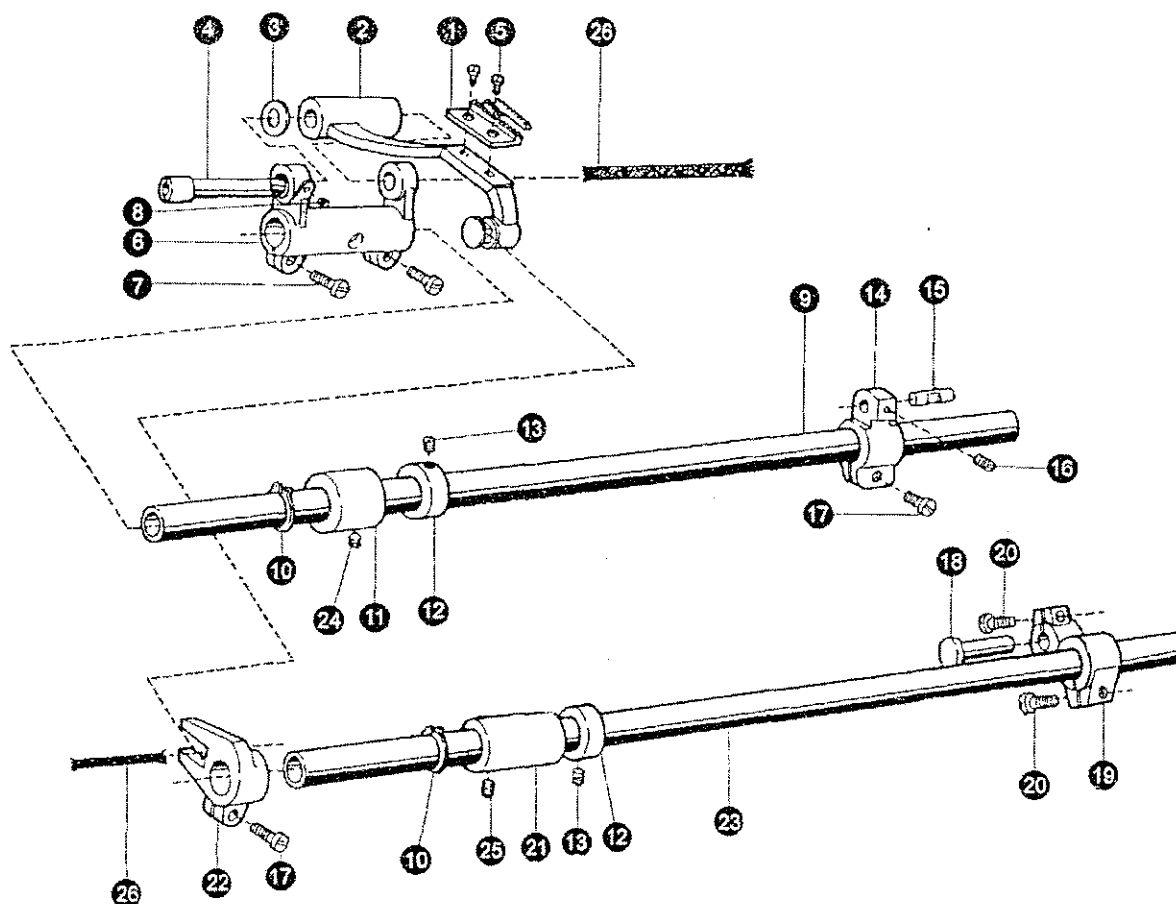

No.	Ref. No.	Description	Pcs.		
			M	H	B
1	22T6 - 001A3	Feed dog	1		
	48T6 - 001A2	Feed dog		1	1
2	36T4 - 001A1a	Feed bar	1	1	1
3	22T6 - 001A6	Washer	1	1	1
4	36T4 - 001A2	Feed bracket shaft	1	1	1
5	22T6 - 001A4	Screw	2	2	2
6	22T6 - 001A1a	Feed rock bracket arm	1		
	48T6 - 001A1a	Feed rock bracket arm		1	1
7	22T6 - 001A1b	Screw	2	2	2
8	22T2 - 019	Screw	1	1	1
9	124T6 - 002	Feed rock shaft	1	1	1
10	GB894 - 76	C - type stop ring (ring 15)	2	2	2
11	22T6 - 004	Feed rock shaft bushing	1	1	1
12	22T6 - 005B1	Collar	2	2	2
13	22T3 - 002B2	Set screw	4	4	4

No.	Ref. No.	Description	Pcs.		
			M	H	B
14	36T4 - 003	Feed rock shaft crank (right)	1		
	114T4 - 001	Feed rock shaft crank (right)		1	1
15	36T4 - 004H01	Feed link stud	1	1	1
16	36T5 - 008E6	Set screw	1	1	1
17	22T6 - 008D3	Screw	2	2	2
18	22T6 - 007	Hinge	1	1	1
19	36T4 - 017	Feed lifting rock shaft crank (right)	1	1	1
20	J0.0.71	Screw	2	2	2
21	22T6 - 012	Bushing for feed lifting rock shaft	1	1	1
22	36T4 - 018H1D1	Feed lifting shaft crank	1	1	1
23	124T6 - 003	Feed lifting rock shaft	1	1	1
24	22T2 - 009	Set screw	1	1	1
25	22T2 - 002	Set screw	1	1	1
26	36T4 - 001A3	Wick	2	2	2

STITCH LENGTH REGULATING MECHANISM

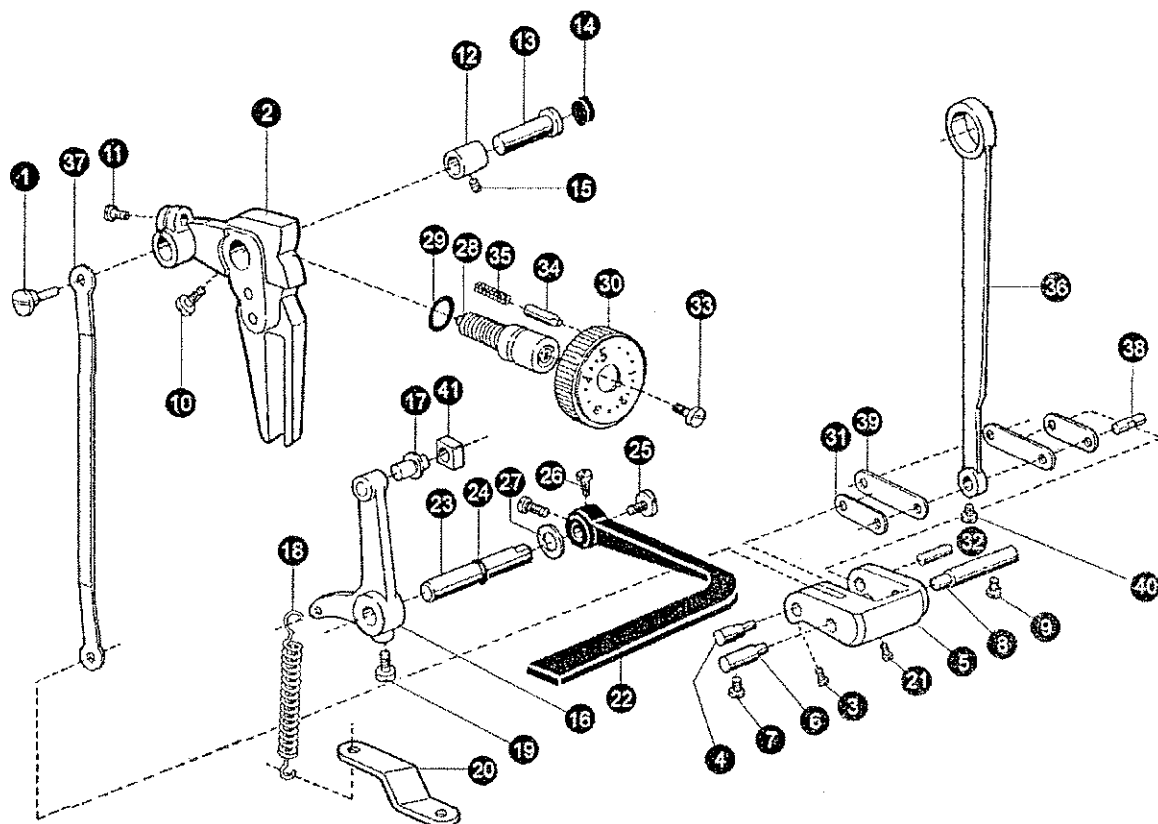

No.	ref. No.	Description	Pcs.		
			M	H	B
1	36T5 - 001	Connectng stud	1	1	1
2	57T5 - 001	Feed regulator	1		
	124T5 - 002	Feed regulator		1	1
3	36T5 - 008E8	Screw	1	1	1
4	36T5 - 008E9	Lever link eccentric shaft	1	1	1
5	36T5 - 008E10	Level regulator	1	1	1
6	36T5 - 009H02	Pin(left)	1	1	1
7	22T6 - 008D3	Screw	1	1	1
8	36T5 - 009H01	Pin(right)	1	1	1
9	22T6 - 008D3	Screw	1	1	1
10	22T5 - 010D4	Screw of feed regulator	1	1	1
11	22T2 - 019	Screw	1	1	1
12	22T5 - 003	Feed regulator bushing	1	1	1
13	22T5 - 004	Feed regulator shaft	1	1	1
14	36T5 - 003	Rubber plug (Φ20)	1	1	1
15	22T2 - 002	Set screw	1	1	1
16	22T5 - 012E1	Backtacking crank	1	1	1
17	22T5 - 012E1a1	Slide block pin	1	1	1
18	57T5 - 004B1	Level spring	1	1	1
19	22T5 - 013	Set screw	1	1	1
20	57T5 - 005	Bracket for spring	1	1	1
21	36T5 - 008E7	Screw	1	1	1
22	22T5 - 010D1	Backtacking fever	1	1	1

No.	Ref. No.	Description	Pcs.		
			M	H	B
23	36T5 - 006C1a1	Backtacking lever shaft	1	1	1
24	22T5 - 010D2b	O - ring	1	1	1
25	22T5 - 010D3	Screw	1	1	1
26	22T5 - 010D4	Screw	2	2	2
27	22T5 - 011	O - ring	1	1	1
28	22T5 - 006C1	Feed regulator screw	1	1	1
29	124T5 - 001A3	O - ring for feed regulating screw	1	1	1
30	124T5 - 001A1 - 1	Knob	1		
	124T5 - 001A1 - 2	Knob		1	1
31	36T5 - 008E4H01	Feed rock link	1	1	1
32	36T5 - 008E6	Pin	1	1	1
33	22T5 - 006C3	Screw	1	1	1
34	22T5 - 008	Stopper pin	1	1	1
35	22T5 - 009	Spring for stopper pin	1	1	1
36	36T5 - 008E2	Level feed connecting rod	1	1	1
37	36T5 - 008E3	Feed regulator link	1	1	1
38	36T4 - 004H02	Link shaft	1	1	1
39	36T5 - 008E4H02	Feed rock arm link	2		
	114T5 - 003	Feed rock arm link		2	2
40	36T5 - 008E5	Screw	1	1	1
41	22T5 - 012E1a2	Crank slide block	1	1	1

PRESSER FOOT MECHANISM

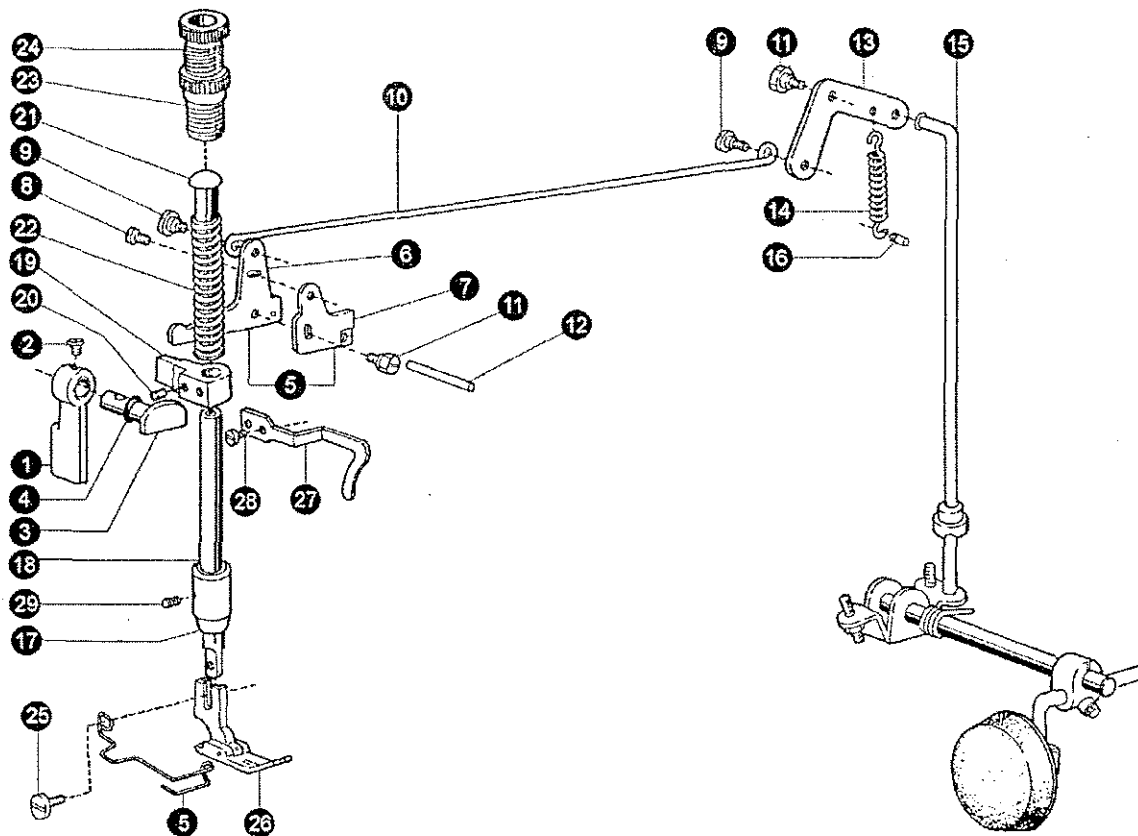

No.	Ref. No.	Description	Pcs.		
			M	H	B
1	22T7 - 001A	Presser bar lifter	1	1	1
2	22T7 - 006	Set screw	1	1	1
3	22T7 - 002	Presser bar lifter	1	1	1
4	GB1235 - 76	Oil seal for presser bar	1	1	1
5	57T7 - 002	Presser foot spring	1	1	1
6	22T7 - 004B1a	Knee lifter lever (left)	1	1	1
7	22T7 - 004B1b	Tension releasing cam	1	1	1
8	22T7 - 004B1c	Screw	1	1	1
9	22T7 - 004B2	Hinge screw	2	2	2
10	22T7 - 004B3	knee lifter rod	1	1	1
11	22T7 - 005	Bolt for tension releasing cam	1	1	1
	22T7 - 005	Screw	1	1	1
12	22T7 - 006	Tension releasing pin	1	1	1
13	22T7 - 007C1	Knee lift lever (right)	1	1	1
14	22T7 - 007C2	Spring for knee lifter lever (right)	1	1	1
15	22T7 - 007C3	Knee lifter connecting rod	1	1	1

No.	Ref. No.	Description	Pcs.		
			M	H	B
16	22T7 - 008	Pin for spring	1	1	1
17	22T7 - 009	Presser bar bushing	1	1	1
18	22T7 - 010	Presser bar	1	1	1
19	22T7 - 011D1	Presser bar lifting bracket	1	1	1
20	22T1 - 013	Set screw	1	1	1
21	22T7 - 012	Presser bar guide	1	1	1
22	22T7 - 013	Presser spring	1		
	48T7 - 002	Presser spring		1	1
23	22T7 - 014E1	Presser regulating thumb screw	1	1	1
24	22T7 - 014E2	Lock nut	1	1	1
25	22T7 - 015	Set screw	1	1	1
26	22T7 - 017F	Presser foot complete	1		
	48T7 - 003A	presser foot complete		1	1
27	22T2 - 009	Slack thread regulator	1	1	1
28	22T7 - 004	Screw	1	1	1
29	22T - 013	Set screw	1	1	1

LUBRICATION SYSTEM

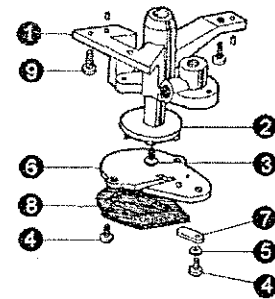
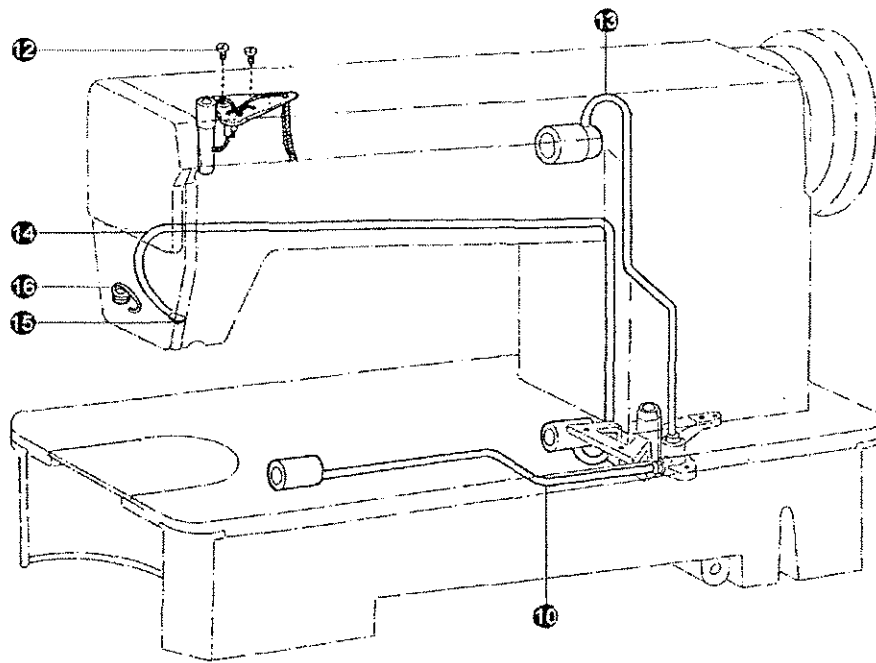

No.	Ref. No.	Description	Pcs.		
			M	H	B
1	22T8 - 001	Oil pump body	1	1	1
2	22T8 - 002	Oil pump impeller	1	1	1
3	22T8 - 003	Screw	1	1	1
4	22T8 - 004	Screw	3	3	3
5	22T8 - 005	Spring washer	1	1	1
6	22T8 - 006	Oil pump fitting plate	1	1	
	78T8 - 001	Oil pump fitting plate			1
7	22T8 - 007	Oil adjusting plate	1	1	1
8	22T8 - 008A	Oil pump screen complete	1	1	1

No.	Ref. No.	Description	Pcs.		
			M	H	B
9	22T8 - 009	Screw	3	3	3
10	22T8 - 010B	Oil pipe for hook shaft	1	1	1
11	22T8 - 011C	Oil braid fitting plate	1	1	1
12	22T7 - 015	Screw	2	2	2
13	22T8 - 013D	Oil pipe for arm shaft	1	1	
	78T8 - 002A	Oil pipe for arm shaft			1
14	22T8 - 014	Oil returning pipe	1	1	1
15	22T8 - 015	Felt pouch for return oil filter	1	1	1
16	36T10 - 002	Oil returning pipe holder	1	1	1

OIL RESERVOIR AND OTHER ACCESSORIES

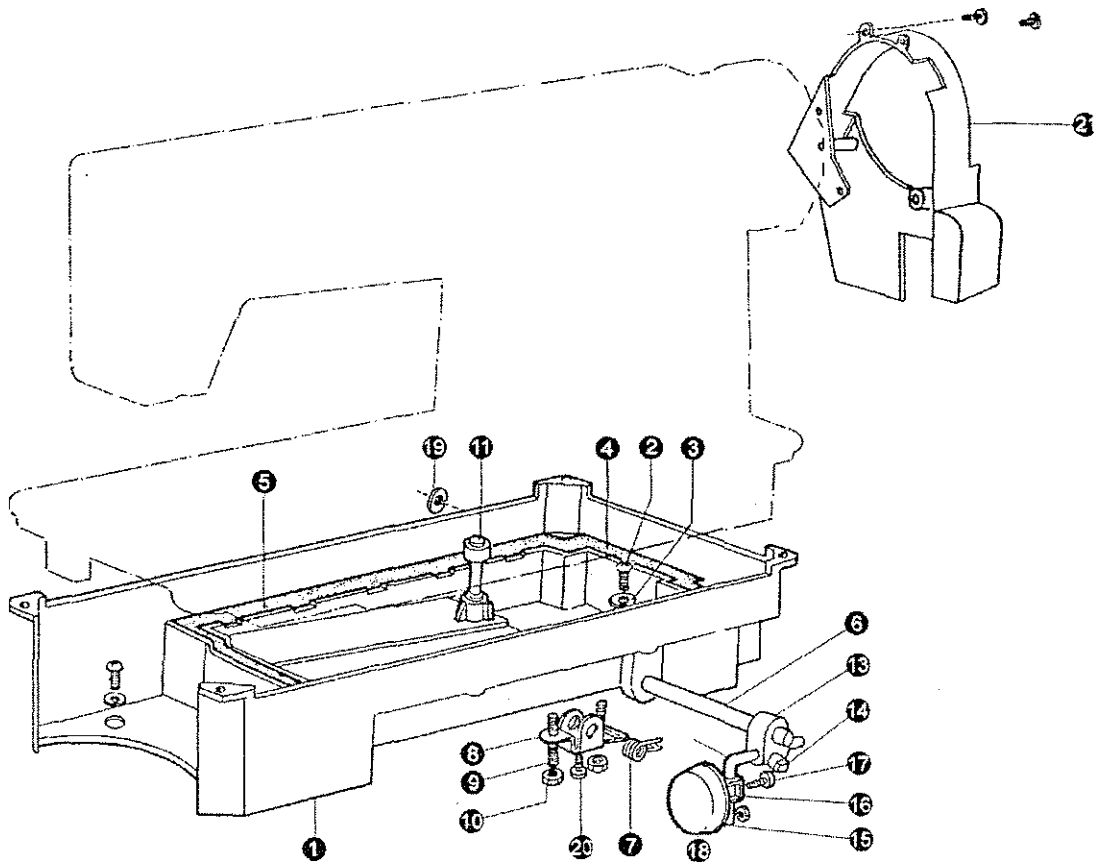

No.	Ref. No.	Description	Pcs.		
			M	H	B
1	22T9 - 001A1	Oil reservoir	1	1	1
2	22T9 - 001A2	Oil drain screw	2	2	2
3	22T9 - 001A3	Washer	2	2	2
4	22T9 - 001A4	Gasket for oil reservoir(S)	1	1	1
5	22T9 - 001A5	Gasket for oil reservoir(B)	1	1	1
6	22T9 - 001A6	Hinge pin for knee lifter lever	1	1	1
7	22T9 - 001A7	Back spring for knee lifter	1	1	1
8	22T9 - 001A8	Knee lifter stop bracket	1	1	1
9	22T9 - 001A9	Adjusting screw	2	2	2
10	22T9 - 001A10	Lock nut	2	2	2
11	22T9 - 003B1	Knee lifter lifting rod	1	1	1

No.	Ref. No.	Description	Pcs.		
			M	H	B
12	22T9 - 003B2	Knee lifter bell crank	1	1	1
13	22T9 - 001B3	Knee lifter bell crank joint	1	1	1
14	GB5781 - 86	Set screw	2	2	2
15	22T9 - 003B5	Knee lifter plate	1	1	1
16	22T9 - 003B6	Bracket for knee lifter plate	1	1	1
17	22T9 - 003B7	Set screw	1	1	1
18	22T9 - 003B8	Pat for knee lifter plate	1	1	1
19	GB896 - 76	C - type stop ring	1	1	1
20	22T9 - 035	Screw	1	1	1
21	22T9 - 004C	Belt cov	1	1	1

BOBBIN WINDER, SPOOL STAND MECHANISM

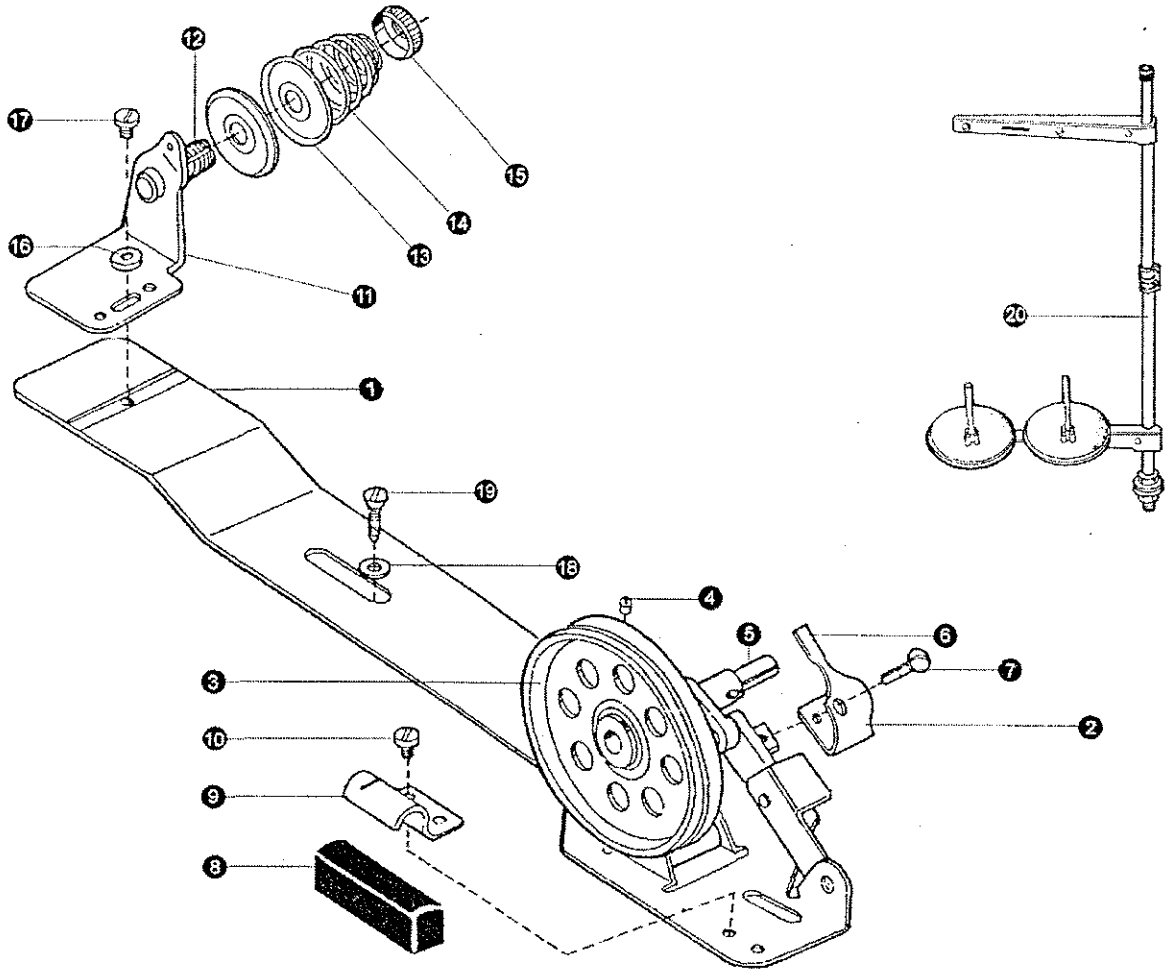

No.	Ref. No.	Description	Pcs.		
			M	H	B
1	6F0-001A	Bobbin winder base	1	1	1
2	6F0-001A6a	Bobbin winder stop latclever set	1	1	1
3	6F0-002	Bobbin winder pulley	1	1	1
4	01/B112	Screw	1	1	1
5	6F0-003	Bobbin winder spindle	1	1	1
6	6F0-004-1	Bobbin winder stop latch	1	1	
	6F0-004-2	Bobbin winder stop latch			1
7	6F0-005	Adjusting screw	1	1	1
8	6F0-006	Stoper block	1	1	1
9	6F0-007	Stoper block clamp	1	1	1
10	6F0-008	Set screw	1	1	1

No.	Ref. No.	Description	Pcs.		
			M	H	B
11	6F0-009B1b1	bobbin winder tension bracket	1	1	1
12	17T7-017	Bobbin winder tension stud	1	1	1
13	22T1-012F5	Bobbin winder tension discs	2	2	2
14	22T1-012F3	Bobbin winder tension spring	1	1	1
15	J2.2.7	Tension stud nut	1	1	1
16	BQ10021	Washer	1	1	1
17	22T2-004	Tension bracket screw	1	1	1
18	BQ10021	Washer	2	2	2
19	GB99-76	Wood screw	2	2	2
20	GXJ-2	Spool stand	1	1	1

ACCESSORIES

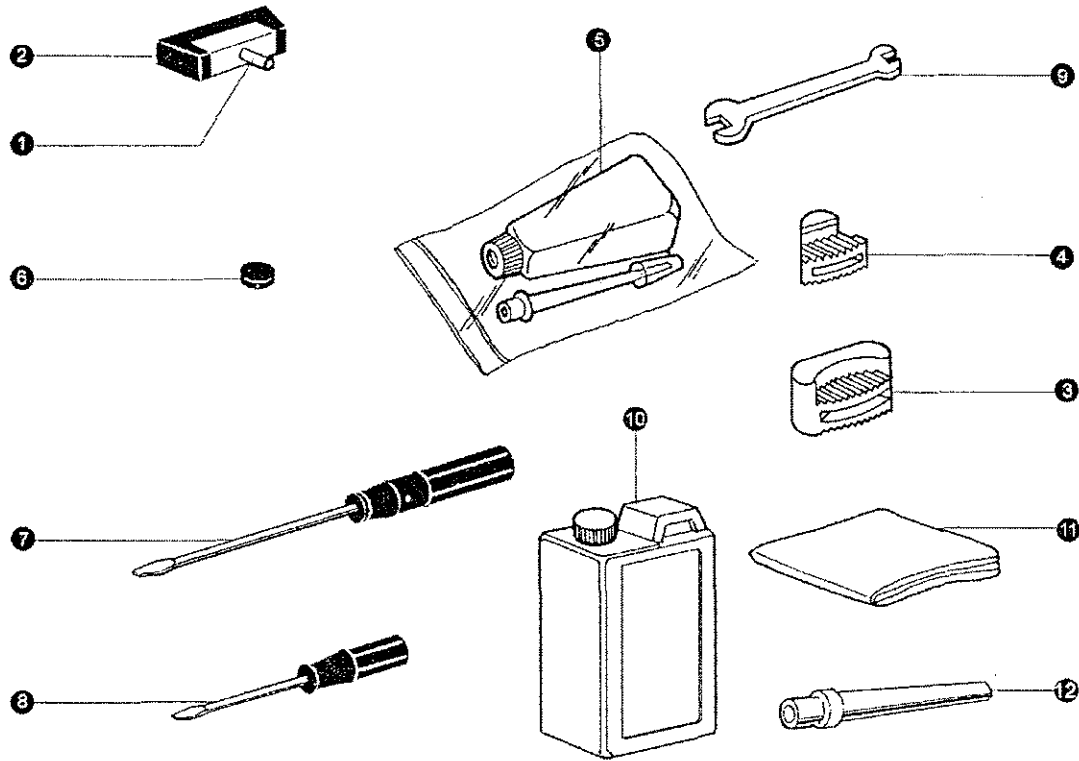

No.	Ref. No.	Description	Pcs.		
			M	H	B
1	22T9 - 007F1	Hinge of machine head	2	2	2
2	22T9 - 007F2	Hinge socket of machine head	2	2	2
3	22T9 - 009	Rubber cap (Big)	2	2	2
4	22T9 - 010	Rubber cap (small)	2	2	2
5	22T9 - 011	Oil pot	1	1	1
6	22T9 - 012	Magnet	1	1	1

No.	Ref. No.	Description	Pcs.		
			M	H	B
7	22T9 - 013	Screw driver (large)	1	1	1
8	22T9 - 015	Screw driver (small)	1	1	1
9	22T9 - 016	Double end wrench	1	1	1
10	22T9 - 017	Oil can	1	1	1
11	22T9 - 018	Vinyl cover	1	1	1
12	124T9 - 002	Head prop pole	1	1	1

Consolidated Sewing Machine Corp.

Website: www.consew.com

MAIN office

131 W. 25th Street
New York, NY 10001
Tel: 212-741-7788
Fax: 212-741-7787
e-mail: consew@att.net

Miami, FL

4013 N.W. 79th Avenue
Miami, FL 33166
Tel: 305-471-0200
Fax: 305-471-0243
e-mail: miamisales@consew.com

Los Angeles, CA

2320 South Hill Street
Los Angeles, CA 90007
Tel: 213-745-8844
Fax: 213-745-8855
e-mail: lasales@consew.com